

HYBRID ACTIVE POWER FILTER METHOD IN FREQUENCY DOMAIN FOR QUALITY IMPROVEMENT IN VARIABLE FREQUENCY DRIVE APPLICATIONS

Minh Hoang Hac Le^a, Kim-Anh Nguyen^{b*}, Viet Hung Ngo^c

^aPowerMore Ltd. company, Danang, Vietnam

^bFaculty of Electrical Engineering, the University of Danang, University of Science and Technology, Vietnam

^cPower Generation Corporation 2 (GENCO2) - Vietnam Electricity (EVN), Vietnam

Article history

Received

17 July 2015

Received in revised form

29 November 2015

Accepted

16 Jan 2016

*Corresponding author

anh.nk@powermore.vn

Graphical abstract

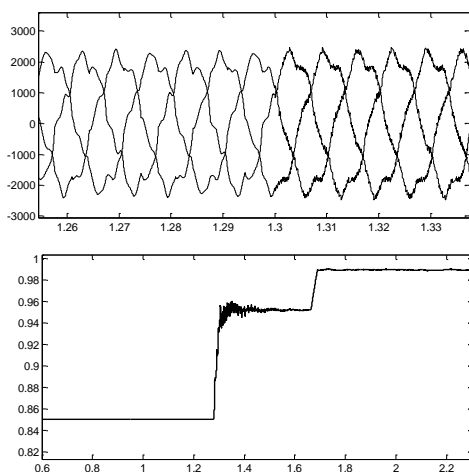

Abstract

We present in this paper a control method of a novel hybrid parallel active power filter (HPAPF) used for harmonic currents elimination and reactive power compensation in the power system for three-phase variable frequency drives (VFDs). The HPAPF configuration is built from two filter components including harmonics tuned passive filter and active power electronics filter. The active power electronics filter of the proposed HPAPF system is controlled by a novel control algorithm that makes use of Fourier analysis to facilitate accurate selective harmonics targeting allowing the cooperation between passive and active components. In the proposed topology, a coupling of the passive filter component and the active filter allows significant reduction in current rating of the active filter component. This rating reduction scheme implies a great economic advantage of the proposed HPAPF compared to the methods which are based only on traditional pure active power electronics filters. The hardware design and the control algorithm of the proposed HPAPF are verified by MATLAB/Simulink software.

Keywords: Hybrid parallel active power filter; shunt active power filter; passive filter; selective harmonics filtering; variable frequency drive.

© 2016 Penerbit UTM Press. All rights reserved

1.0 INTRODUCTION

In recent years, the advancement of industrial product quality and production precision require new breeds of accurate and efficient equipment. This leads to the increase of nonlinear loads which, in turn, creates a rapid deterioration of power quality in multiple industrial fields. Variable frequency drive (VFD) is among the most prominent sources of poor power quality including electric arc furnaces, induction furnaces, power rectifier, computing centers, etc. VFD is typically used in speed control, HVAC, flow rate control, factory packaging and transportation, etc. Nonlinear loads produce harmonics [1] and consume a significant amount of reactive power

[2]. Additionally, reactive power consumption of VFDs changes constantly over time resulting in sags, swells, flicker and other disturbances [3]. Serious current harmonics pollution could affect the whole distribution grid by causing voltage harmonics because of the fact that bus bar voltage is coupled with line current by line parasitic impedance [4]. Finally, reactive power is required to maintain the voltage to deliver active power. Though reactive power is needed by many electrical devices, excessive fluctuation and abnormal transients could lead to equipment damage [5]. This is why most of research works concerning the power quality reported in the literatures are interested in the

matter of current harmonics cancellation and dynamic reactive power compensation [6].

Over the past few decades, the history of power filters has gone through a changing process from passive power filters (PPFs) [7-8] to active power filters (APFs) [9-10], and recently, towards hybrid active power filters (HAPFs) [11-13]. Different topologies of HAPF composed of active and passive equipment have been proposed, aiming to improve the compensation characteristics of PPFs and reduce the voltage and/or current ratings and cost of the APFs [14]. Jasmine Susila et al. have implemented a series topology HAPF in [15], simulation results showed improved power quality. However, their proposed topology was not fully tested due to inadequate experimental setup. Mehdi Asadi et al. [16] proposed a HPAF which comprises a b-shape C-type HAPF (bCHAPF) and an active electromagnetic filter consisting of a Zig-Zag transformer and a single-leg inverter, the topology performed well with current harmonics elimination but complex and difficult to implement.

In this paper, a joint topology of active filter and passive filter for current harmonic cancellation and power factor enhancement in three-phase power networks is proposed and studied. The topology is a parallel configuration of low order passive harmonics filter and selective shunt active power filter. Frequency domain Fourier Transform analysis and robust PI controllers are used to design control algorithm. HPAPF performance is verified by modeling and using Matlab/Simulink software for model simulations.

2.0 CONSTRUCTION OF PROPOSED HPAPF

2.1 Design of Passive Components

Single tuned topology is chosen to implement the passive components because it is simple to construct and economically viable. Along with high pass and double tuned filters, single tuned passive filter is one of the most commonly used type of harmonics filters in three-phase systems.

The passive components of the joint topology are designed to eliminate the majority of the lower part of the harmonic spectrum, typically 5th and/or 7th harmonics. The quality factor of the filter Q is typically chosen in the range of 15 to 80 and inversely proportional to filter branch resistance.

Filter tuning frequency f_h and tuning angular frequency w_h are calculated as,

$$f_h = \frac{1}{2p\sqrt{LC}}, w_h = \frac{1}{\sqrt{LC}} \tag{1}$$

The relationship between filter inductance L and capacitance C is presented as,

$$Z_{L,h} = Z_{C,h} \text{ @ } L = \frac{1}{(hw_{50Hz})^2 C}, \tag{2}$$

where $Z_{L,h}$ and $Z_{C,h}$ are filter inductor and capacitor impedances at f_h , h is the harmonic order of the passive

branch, w_{50Hz} is the angular frequency at fundamental frequency.

Filter quality factor Q is calculated as,

$$Q = \frac{Z_L}{R} = \frac{1}{R} \sqrt{\frac{L}{C}}, \tag{3}$$

Whereas Z_L is inductor impedance at fundamental frequency.

In Figure 1, two PHF branches are connected in parallel and tuned at 5th (L_{f1}, C_{f1}, R_{f1}) and 7th (L_{f2}, C_{f2}, R_{f2}). Along with harmonics filtering functionality, the two passive branches also provide background reactive power compensation for power factor correction.

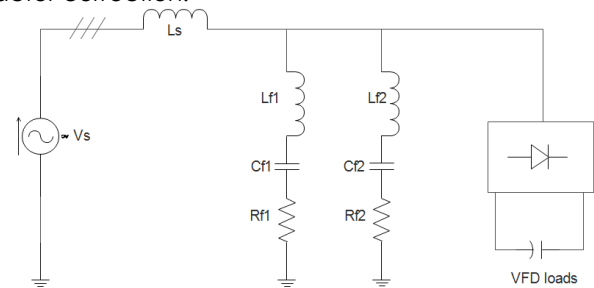

Figure1 Single tuned passive filter diagram

For power factor correction from an initial $PF_{initial}$ to a desired PF_{final} value, the amount of reactive power produced by the passive component Q_{filter} is calculated as follow:

$$Q_{filter} = P_{load}(\tan[\arccos(PF_{initial})] - \tan[\arccos(PF_{final})]) \tag{4}$$

Q_{filter} can also be calculated as,

$$Q_{filter} = Q_C - Q_L = \frac{h^2 - 1}{h^2} Q_C. \tag{5}$$

When Q_C is obtained, C and L can be found as describe in [6]. Finally, R can be calculated via selection of quality factor.

Figure 2 shows the frequency response of a passive filter in which the local maximum shows a parallel resonance between the filter and grid due to grid parasitic impedance. The filter impedance minimum situates at tuning frequency.

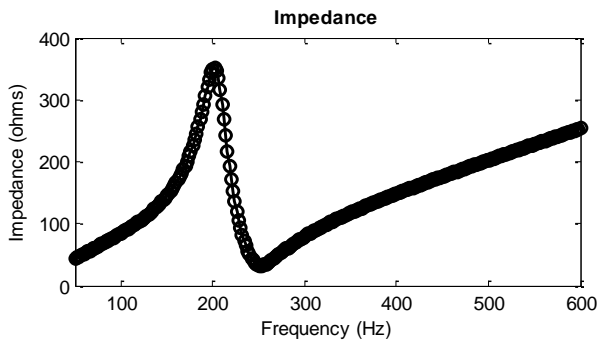

Figure 2 Branch Impedance versus Frequency diagram of a typical single tuned passive filter

2.2 Design of Active Component

The active component of the joint topology is a shunt APF with small compensation current rating shown in Figure 3. As the active power filter is placed upstream of the passive components, it will only see high order harmonics which are typically 11th, 13th,... since lower harmonics are eliminated by the passive components. In VFD systems, harmonics magnitudes tend to decrease as harmonic order increases. [17]

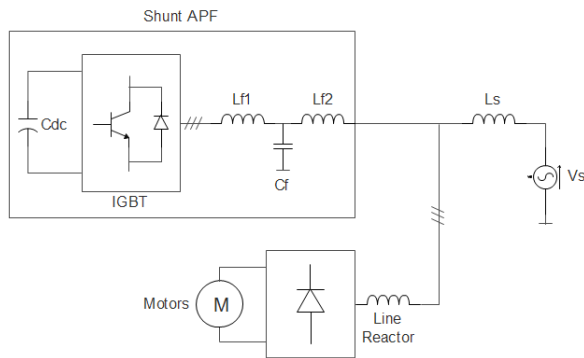

Figure 3 Structure and wiring diagram of a shunt APF

In principle, the active filter stores electrical energy in its DC bus and convert this DC voltage into three phase AC voltage and AC current. The control algorithm decides how much reactive power is being supplied to the grid by varying the output current phase and amplitude. This can be achieved by estimating the correct amount of reactive power needed by the non-linear loads using voltage and current feedback signals measured at the point of common coupling (PCC) and DC bus. Details about the control algorithm will be further discussed in the next section.

3.0 CONTROL METHODOLOGY

3.1 Frequency Domain Analysis of Harmonics Current

Fourier Transform is used to analyse load feedback signal to provide flexible selective harmonics compensation.

Discrete Fourier Transform (DFT) is the digital form of Fourier Transform. DFT of a discrete signal sampled *N* times in a cycle is defined:

$$X_1 = \sum_{k=0}^{N-1} x_k e^{-j2\pi k/n} \tag{6}$$

Inverse DFT of *X*₁ is defined as:

$$x_{k1} = \frac{1}{N} X_1 e^{-j2\pi k/n} \tag{7}$$

This allows the selection of high order harmonics while omitting lower components. According to Fourier Transform, load current can be represented as:

$$i_{load}(t) = i_{load1}(t) + \sum_{n=2}^{\infty} i_{load,n}(t) \tag{8}$$

Whereas function *i*_{load1}(*t*) represents the fundamental and *i*_{load,n}(*t*) is the function of harmonic components.

3.2 APF Reference Current Calculation and Control Loops For Compensation Current Generation

Figure 4 illustrates the control algorithm for the active component. Assuming a sampling rate of 12800 Hz, which is 256 samples/electrical cycle, the amount of frequency bin obtained by DFT is 256 bins. These bins represent 128 frequency components of load current. Reference current is computed by extracting high order harmonics from DFT analysis of load feedback current, namely 11th to 128th frequency bins, and then takes the inverse DFT of this frequency range.

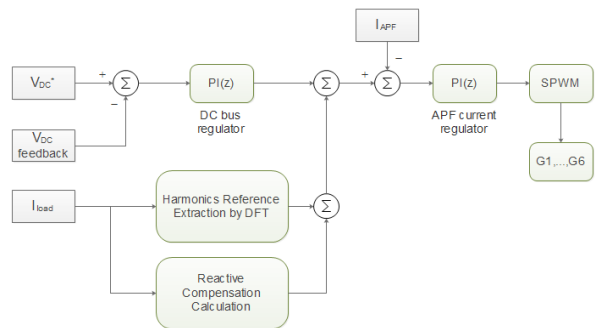

Figure 4 Control algorithm for the active component

A DC bus voltage PI regulator is included in order to keep DC bus stable at a reference value. Output of the DC bus PI regulator is then added to harmonics reference current along with reactive power compensation reference current. Another PI controller is used to generate pulse width modulation signals and regulate APF output compensation current. PWM generation module is a Sinusoidal PWM which creates

PWM pulses at a specific switching frequency, normally between 8 kHz to 15 kHz.

4.0 SIMULATION RESULTS

4.1 Case Study of a VFD System

For the purpose of demonstrating the performance of the HPAPF, a case study is conducted at a cable car transport system as seen in Figure 5. The cable car system is located in Danang, Vietnam. Power quality parameters for the case study are obtained by an Elspec G4500 Blackbox industrial monitor. In this case, the harmonics pollution exemplifies the harmonics generating characteristic of DC drives in an industrial application. The electrical system at Station 6 consists of a pair of 575 kW DC motors driven by two ABB DCS800 DC drives, supplied by a 2 MVA 22kV/0.4kV Delta/Wye Transformer.

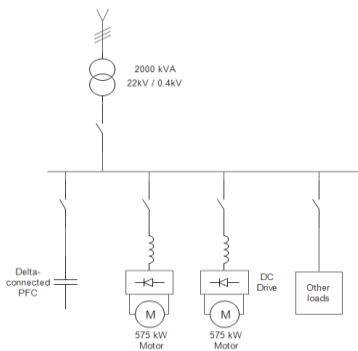

Figure 5 Basic electrical diagram of the cable car transport system using DC drives in Danang, Vietnam

These nonlinear loads have been generating severe harmonics with current THD fluctuates between 26.3% and 112.6%. Voltage THD is also high, consistently above 13% and peaks at 26.3%.

High harmonic current and voltage have dealt significant damages to the cable car system, interrupting the cable car lifting operation of the motors and causing considerable business downtime.

4.2 Implementation of Proposed Topology for the Case Study

For the case study, we propose a HPAPF topology in which, both of passive filter components and active filter component are included and configured as presented in Figure 7. The existing power factor correction capacitor bank on site is removed because it was producing parallel resonance in the system, making 11th and 13th harmonics current unusually high as seen in Figure 6.

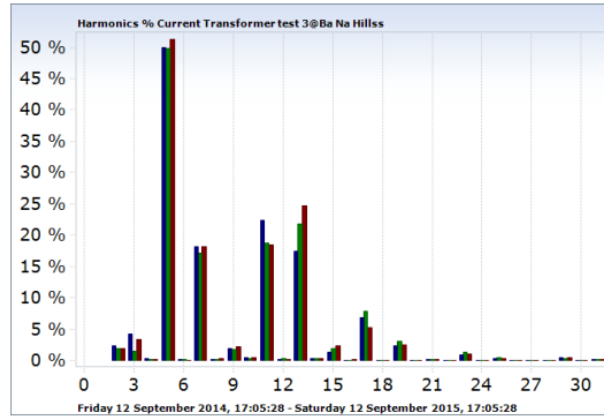

Figure 6 Measured harmonics spectrum shows significant harmonics at 5th, 7th, 11th and 13th orders

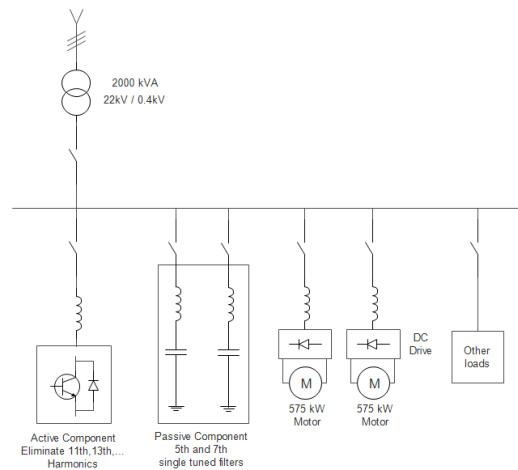

Figure 7 HPAPF with active and passive components installed

As initial power factor is 0.85, the amount of reactive power needed by the 1100 kW DC motors and other loads, Q_{total} , could be calculated as,

$$Q_{total} = 1100kW' (\tan[\arccos(0.85)] - \tan[\arccos(0.95)]) = 320 \text{ kVAr.}$$

The active component harmonics rating is selected to be 220Arms for the elimination of harmonics orders of 11th, 13th, and above. DC bus is regulated at 620V with DC capacitance $C_{DC} = 3500mF$. APF interface filter inductance is chosen as $L_{interface} = 0.37mH$. The IGBT switches are driven by an 8 kHz PWM pulse generator.

Passive components effectively reduce current THD from 33.6% to 13.5% by trapping 5th and 7th harmonics (see Figure 8). In order to avoid overloading, and due to parameter discrepancy, 5th and 7th filter branches do not resonate at exactly 250 Hz and 350 Hz but rather 247.5 Hz and 347.5 Hz. Consequently, 5th and 7th harmonics are not entirely eliminated. In addition, the current transient occurs at 1s is characteristic of capacitor switching.

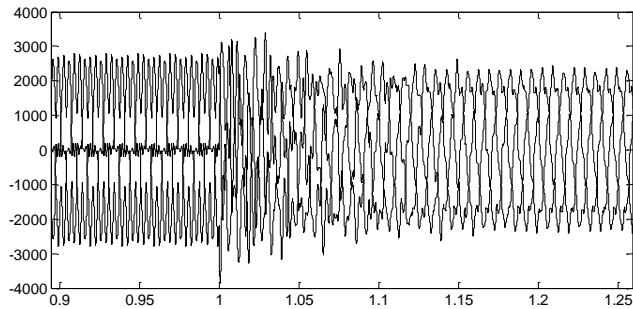

Figure 8 Nonlinear current being filtered by the passive components

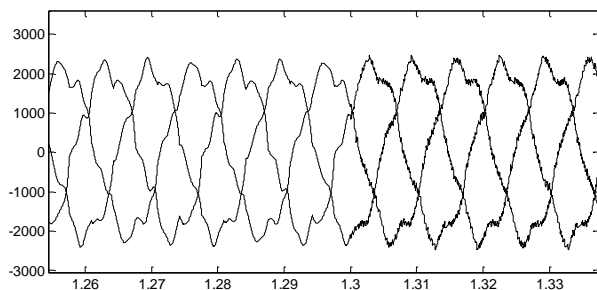

Figure 9 Nonlinear current being compensated with the passive components and the active component

In Figure 9, the active component is switched on at 1.3s after the source current becomes stable. High frequency fluctuation is considerably reduced since 11th and 13th are eliminated and current THD is further decreased to 10.1%.

Figure 10 shows power factor correction from 0.85 to 0.95 by connecting the passive components at 1.3s. At 1.7s, the active component is connected and improves the power factor to 0.98.

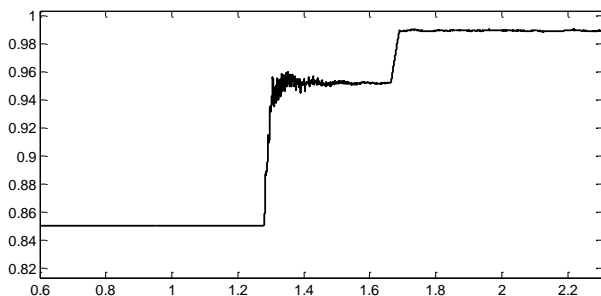

Figure 10 Power factor correction of the joint topology, active component connected at 1.7 s

A comparison between a typical shunt APF and the joint topology is done by measuring the amount of compensating current produced by each type of device. Figure 11 shows the reduction of RMS current rating of the active component when the active component RMS rating to only 32% of a shunt APF's (220 Arms compared to 680 Arms) for this case study.

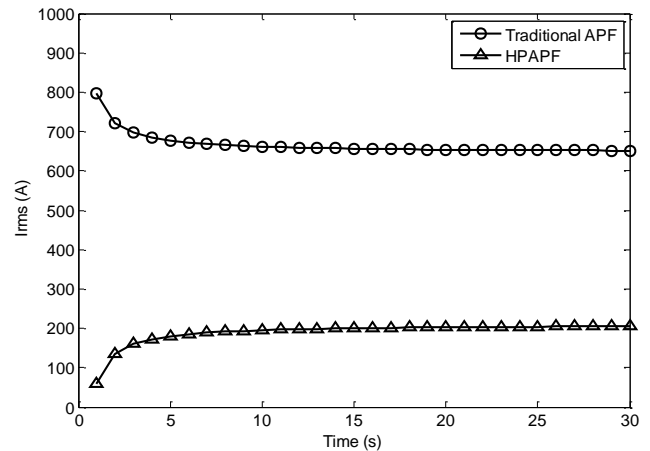

Figure 11 Comparison of compensation RMS current between pure shunt APF and HPAPF

5.0 CONCLUSION

The paper demonstrates the effectiveness of the proposed HPAPF in the harmonics cancellation and the dynamic reactive compensation in a VFD system. The obtained results show that the active component RMS current rating in the HPAPF system is only 32% of the traditional filtering performance. This reduction in rating implies a great economic advantage of the proposed HPAPF compared to the traditional APFs. Moreover, the proposed HPAPF shows significant potential in installation footprint reduction, which is important in space constraint sites such as cruise ships, oil rigs, etc.

Future works involves thermal design of the active component and a detailed transient analysis of HPAPF system. Furthermore, an electrical prototype will also be developed to verify real-world performance.

Acknowledgement

This work is partially supported by the PowerMore Ltd. Company, Vietnam.

References

- [1] Akagi, H. 2006. Modern Active Filters And Traditional Passive Filters. *Bulletin of the Polish Academy of Sciences Technical Sciences*. 54(3): 255-269.
- [2] Nguyen, K.A. and Bui, Q.K. 2009. An Active Filters Design For The Reduction Of Current Harmonic And The Compensation Of Reactive Power For Induction Melting Furnace Power. *Journal Of Science & Technology, the University of Danang*. 4(33): 35-42.
- [3] Yasir, M., Kazemi, S., Lehtonen, M. and Fotuhi-Firuzabad, M. 2012. Optimal Selection Of Voltage Sag Mitigation Solution Based On Event Tree Method. *Proc. on Electric Power Quality and Supply Reliability Conference (PQ)*.1-6.
- [4] Grady, W. M., Samotyj, M. J. and Noyola, A. H. 1992. The Application Of Network Objective Functions For Actively Minimizing The Impact Of Voltage Harmonics In Power

- Systems. *IEEE Transactions on Power Delivery*. 7(3): 1379-1386.
- [5] Godbole, P. 2014. Effect Of Harmonics On Active Power Flow And Apparent Power In The Power System. *IOSR Journal of Electronics and Communication Engineering (IOSR-JECE)*: 39-43.
- [6] Singh, B., Al-Haddad, K. and Chandra, A. 1999. A Review of Active Filters for Power Quality Improvement. *IEEE Transactions On Industrial Electronics*. 46(5).
- [7] Tupsa-ard, J., Chamchoy, C. and Tayjasanant, T. 2011. High voltage passive harmonic filter design. *Proc. on Electrical Engineering/Electronics, Computer, Telecommunications and Information Technology (ECTI-CON) International Conference*. 804-807.
- [8] Das, J. C. 2003. Passive Filters-Potentialities And Limitations. *Proc. on Pulp and Paper Industry Technical Conference, Conference Record of the 2003 Annual*, IEEE.187-197.
- [9] Tang, Y., et al. 2012. Generalized Design of High Performance Shunt Active Power Filter with Output LCL filter. *IEEE Transactions on Industrial Electronics* 59(3): 1443-1452.
- [10] Akagi, H., Akira N. and Satoshi A. 1986. Control Strategy Of Active Power Filters Using Multiple Voltage-Source PWM converters. *IEEE Transactions on Industry Applications*. 3: 460-465.
- [11] Bhavaraju, V. B. and Prasad, N. E. 1993. Analysis And Design Of An Active Power Filter For Balancing Unbalanced Loads. *IEEE Transactions on Power Electronics*. 8(4): 640-647.
- [12] Demirdelen, T., et al. 2013. Review of hybrid active power filter topologies and controllers. *Proc. of Fourth International Conference on Power Engineering, Energy and Electrical Drives (POWERENG)*, IEEE.
- [13] Kim, S. and Prasad N. E. 2002. A new hybrid active power filter (APF) topology. *IEEE Transactions on Power Electronics*. 17(1): 48-54.
- [14] Luo, A. et al. 2009. Development of hybrid active power filter based on the adaptive fuzzy dividing frequency-control method. *IEEE Transactions on Power Delivery*. 24(1): 424-432.
- [15] Tzung-Lin, L., Yen-Ching, W., Jian-Cheng, L. and Guerrero, J.M. 2015. Hybrid Active Filter With Variable Conductance for Harmonic Resonance Suppression in Industrial Power Systems. *IEEE Transactions on Industrial Electronics*. 62(2): 746-756.
- [16] Susila, D.J. and Rajathy, R. 2013. Power Quality Enhancement Using Hybrid Active Filter. *International Journal of Engineering Science and Innovative Technology (IJESIT)*. 2(3):81-89.
- [17] Asadi, M. and Jalilian, A.R. 2012. A Hybrid Active Power Filter Comprising an Active Electromagnetic Filter. *Przegląd Elektrotechniczny (Electrical Review)*, ISSN 0033-2097. R. 88 NR 10a.
- [18] Peeran, S. M., and Creg, W. P. C 1995. Application, Design, And Specification Of Harmonic Filters For Variable Frequency Drives. *IEEE Transactions on Industry Applications*. 31(4): 841-847.